

GABRIEL ALEXANDER KHOURY

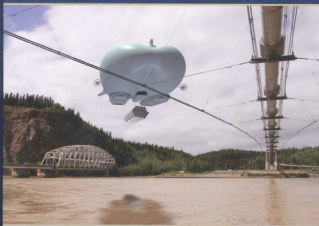

AIRSHIP TECHNOLOGY

SECOND EDITION

CAMBRIDGE

23 Hot Air Airships

Karl Ludwig Busemeyer

Background and History

Along with the general renaissance of the hot air balloon, some forty years ago, a new type of airship entered the scene using hot air as its lifting medium. In the mid-1970s, Cameron Balloons UK started selling these aircraft for sport and aerial advertising purposes. In general, these early hot air airships were 'elongated dirigible hot air balloons'. Shape and stability were dependent solely on the natural hot air pressure as it is with ordinary hot air balloons. As single-seaters they were simple to build and operate, because many technical features had been derived from hot air balloon (or special shape) technology. The single-burner unit is positioned, as in a hot air balloon, under the open belly of the airship envelope. A few Cameron twin-seater hot air airships were built in the late 1970s as well.

Because of their low natural envelope pressure, the use of these airships is extremely dependent on superb weather and virtually restricted to windless conditions. Horizontal manoeuvrability is realised by a propeller slipstream inflated rudder; the rate of climb and descent is dependent on burner input. Maximum speed in calm air is less than 10 knots.

At the beginning of the 1980s, Thunder & Colt Balloons UK produced the first pressurised hot air airship. With the help of a petrol- or propane-driven fan system, and later with the propeller slipstream, the pressure is maintained and controlled inside the airship envelope. The burner unit works now inside the entirely closed envelope. With the introduction of high-tenacity nylon fabrics, the envelope pressure could be increased over the unpressurised airship type and allowed for higher speeds. In the mid-1980s Cameron Balloons also brought a super-pressure airship on the market, followed by Lindstrand Balloons UK in the mid-1990s (Figures 23.1 and 23.2).

Before the Millenium

The majority of hot air airships in the 1990s were pressure airships because of their better performances. Volumes varied between 1,600 m³ for a single-seater and up to 3,000 m³ for a two-seater with some extra payload. Most of the engines in use were two-stroke, varying from 25 to 50hp. The resulting speed was around 10 to

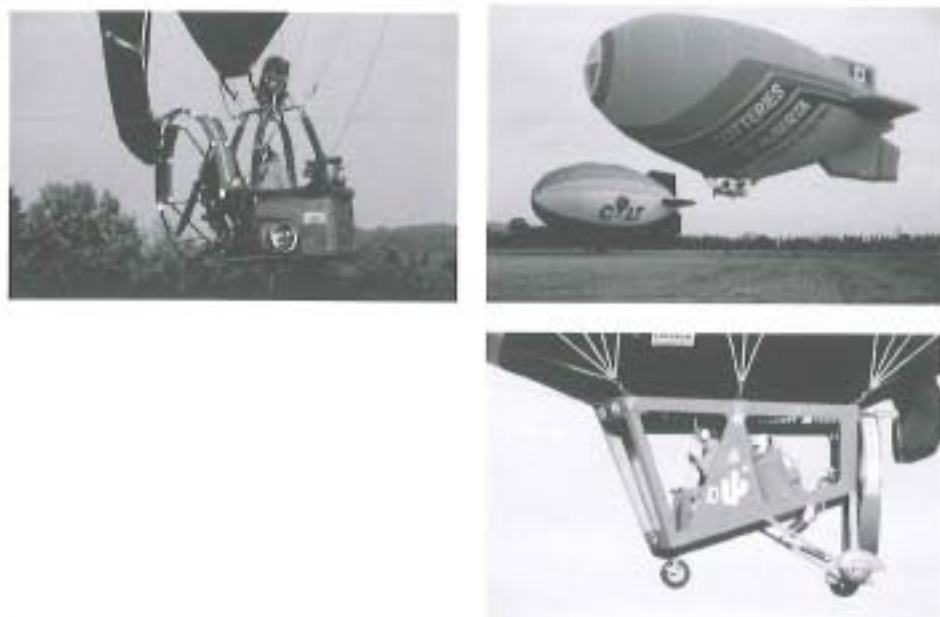

Figure 23.1. Clockwise from top: Cameron single-seater (unpressurised), mid-1970s; Thunder & Colt twin-seater AS 105MK2 in the foreground with another Colt single-seater, mid-1980s (all T&C types are pressurised); Cameron twin-seater gondola (mid-1980s) for pressurised gondolas.



Figure 23.2. Clockwise: Two Cameron airships at the 1st World Championship in Luxembourg 1988, the higher one having a pressurised envelope; 2009 airship parade at Bas Homburg near Frankfurt, in which nine airships took part; Cameron single-seater in the mid-1970s in snowy Switzerland (Chateau D'Oex).

12 knots. Average flight time varied from 45 to 60 minutes with standard airships. Depending on local circumstances and crew skills, hot air airships can be operated at ground wind speeds of 5 to 7 knots. This means that these hot air airships have been as weather-dependent as special-shape balloons. Altogether about 80 to 90 of both airship types have been sold worldwide. In 1988 the first world championship was held, thereby promoting airship technology and pilot skills. Since then several airship championships and 'Grand Prixes' have been held in various countries.

So far the main market for hot air airships has been aerial advertising. There is, however, a steadily increasing market with environmental monitoring and research projects around the world. Because the majority of hot air airships in the 1990s were still technically underdeveloped and therefore very much dependent on suitable weather, they have not as yet been widely accepted and used for these markets.

The German Entry

Since the mid-1970s GEFA-FLUG Ltd, a company based in Aachen, Germany, with today's subsidiaries at Nürnberg and Lake Constance (birthplace of the Zeppelins), has been developing airships. Today GEFA-FLUG is certified as a 'Development and Manufacturing Company' (EASA Part 21) and as an 'Air Operator' organisation as well. The first ten years have been spent with the development and the operation of remote-controlled airships. Since 1985 experiences gained in many countries with big remote-controlled hot air systems for aerial photogrammetry purposes have turned to the development of manned systems.

As a joint venture with Thunder & Colt, and later with Cameron Balloons, the first AS 80 GD was built in 1990 using an upgraded Thunder & Colt twin-seater gondola combined with an envelope entirely designed, built, and certified by GEFA-FLUG. This new envelope type is more streamlined than existing hot air airships, and the maximum forward speed is therefore higher. The general manoeuvrability has also been improved over the years.

Pitch control is possible with the help of a V-form twin-burner arrangement and the resulting improved heat distribution in the envelope fore and aft. To improve the trimming of the ship and to prevent hot air from sloshing backwards and forwards in the envelope, the ship is divided into two parts (front and rear) with the help of a fabric-membrane system. In turbulent air the flight characteristics are now much improved compared with ordinary hot air airships. In addition, the maximum speed is significantly higher owing to their slimmer envelope fineness ratio compared with traditional hot air airships. Envelope lifetime has been improved as well owing to a much better heat distribution.

Quite a few GEFA-FLUG airships, including the AS 80 GD and later the AS 105 GD, have been successfully used for various purposes in more than twenty-five countries around the world. The highlight before the millennium was the introduction of a three/four-seater (depending on climatic conditions) hot air airship with a volume of 3,000 m³. The development of this airship has been partly government-funded. The AS 105 GD has been fully certified in the passenger transport category (EASA Part 21) after a five-year research and development programme.



Figure 23.3. GEFA-FLUG no. 1 airship on its maiden flight in spring 1990. AS80GD uses a twin-seater Thunder & Colt gondola. The fineness ratio of the envelope has been increased to 3:1 to make these airships significantly slimmer and, therefore, faster.

At the time of this writing, airship SN 006 has been delivered to customers in the United States. Airship SN 0057 is under construction (Figure 23.3).

Hot Air versus Helium Airships

Operating gas airships is (very) expensive, for a number of reasons. Conventional large gas airships do need quite a big crew (up to twenty people). Even when not in use they do cost almost the same as during operation (permanent watch, mooring mast, hangar, licensed airfield, helium, crew, and so on). Helium airships therefore are cost-effective only if they will be operated during a high number of months per year.

This is where the hot air airship has a big advantage over the helium one. When not in use, it costs hardly anything because it is stored in a trailer and neither mooring mast, hangar, watch, nor special care are necessary.

The second big advantage is carrying the hot air airship by road to the new place of operation. The helium airship must fly to this place, which turns out to be rather expensive, depending on the distance to the new field of operation. The hot air airship, however, is transported on the road, including its three crew members and the pilot (thereby making 'a couple of days' operation' in one place much less expensive compared with helium airships).

A larger ground crew than three is not necessary because the hot air airship will be inflated and operated only in good flying weather when a large crew is not necessary. The crew of a helium airship must always be large enough to encounter

bad weather periods as well. The crew size of a helium airship therefore varies between roughly 10 and 20, depending on type and size of the ship (the large Hi-Tec Zeppelin NT is an exception in this respect).

Hot air airships have some disadvantages as well. They need more volume to create the same amount of lift and payload. In future, fabrics will be improved and hot air airships will be flown with higher envelope temperatures and will therefore obtain more lift per volume than they do today. With stronger fabrics, the envelope pressure will be increased as well, resulting in a stiffer and therefore more weather-resistant envelope. The difference in lift compared with that of the helium ship will be minimised in the future, although hot air will never reach the lifting capacity of helium.

There is another limitation for hot air airships. As they will always be inflated on the launch field (and not in a hangar), the weather resistance will stay lower than with helium airships (because inflation in open air with strong winds is impossible).

With a professional crew and using an advanced airship such as the AS 105 GD, it becomes possible to stretch the ground wind limit up to 10 or 12 knots. In future it will be possible to extend this limit even up to 15 knots. More than this seems unrealistic because too much effort, more manpower, and high-tech equipment are necessary to inflate the big envelopes in higher wind speeds, thus making flight operations more expensive.

On the other hand, a simple and cheap aircraft can never have a performance level as high as an expensive one. However, the efficiency can be good in both cases, as long as both aircrafts do not compete in the same market niche. The four-seater hot air airship AS 105 GD costs around €200,000 ready to fly. A fully certified four-seater helium airship is about ten times more expensive to buy. It seems likely, however, that there is a market share for both of them, but in different marketplaces.

A large, high-performance airship such as the Hi-Tec Zeppelin NT with its ten to twelve passengers, is even much more expensive, at around €10 million, and aims at a completely different market, with big international corporate clients and long contracts.

Hot Air Airships: General Characteristics

- The price of a hot air airship is much lower than that of a helium airship.
- No hangar is needed; the hot air airship 'lives' in its trailer when not in use.
- The hot air airship is relatively cheap to operate and is still economical even for only a few hours per day.
- Transfer costs to new sites of operation are low because hot air airships travel on the road, not through the air.
- Hot air airships are weather dependent and thermically sensitive; inflation in open air is possible only in low wind speeds. In calm air, however, there is no need for a large operating crew.
- No airfield is necessary; hot air airships take off and land vertically from any given 'suitable place'. Takeoff and landing sites do not need to be certified airfields.
- Small payload limits flight time. Flights will therefore cover only the local area.

- Passenger flying with only one passenger is not cost-effective; however, that changes with sponsored four-seater airships and/or even larger envelopes to carry more people.

First Market for Hot Air Airships: Aerial Advertising

The main market for hot air airships today is the traditional airship market with aerial advertising. Normally hot air airships are operated by companies which might operate hot air balloons as well. Even after the millennium one can describe a hot air airship as a powered, steerable hot air balloon. Many technical features are the same as with balloons, which is a big general safety plus. For example, without an engine a hot air airship can still be flown like a hot air balloon.

The big advantage over the hot air balloon is the engine and the ability to hover over a defined area. Hot air airships are thermically sensitive vehicles, comparable with hot air balloons and similar to other lighter-than-air aircraft. Hot air airships are flown for a couple of hours after sunrise and before sunset, when there is little thermal activity.

There is a good market in visiting fairs, exhibitions, open air and sporting events, and the like in the early evenings. Another possibility is patrolling flights along motorways and trunk roads during traffic jams in the early morning and evening. In wintertime, hot air airships can be operated over ski resorts and can visit big winter games. All these flight profiles are ideal for hot air airships; they are much better suited for these purposes than hot air balloons, which are exclusively 'wind toys'.

GEFA-FLUG hot air airships are certified in the European Aviation Safety Agency EASA passenger transport category and can be used for commercial passenger flying as well. The combination of both advertising and passenger flying in tourist regions makes them even more profitable because it does not cost much to carry hot air airships to their operational theatres on their trailers. They can be transported to places with a high possible number of passengers instead, to try to get the passengers to the airship's permanent base with the help of large marketing budgets.

Second Market: Environmental Monitoring

Hot air airships are suitable for another market: general survey and environmental research. Historically, balloons and airships have always been used for these purposes. There were several airship expeditions in the 1920s and 1930s. Explorers, scientists, and airship commanders such as Roald Amundsen, Umberto Nobile, and Hugo Eckener, with airships such as *Norge*, *Italia*, and *Graf Zeppelin*, are still very well remembered. Airship enthusiasts since then have promoted the use of airships for environmental purposes.

In fact GEFA-FLUG can prove that hot air airships are very suitable for environmental survey and research projects, especially when relatively small areas are to be documented. Hot air airships can really takeoff and land vertically; therefore they need only small launch fields (like hot air balloons), which can always be found close to the flying area. This means that it is inexpensive to get hot air airships to these areas; no expensive flight time is lost in getting there, thereby losing large parts of the monitoring research budget (in contrast with a helium airship).



Figure 23.4. AS 105 GD (four-seater) carrying a 200-kg ground-penetrating antenna for geophysical survey. The project is a joint venture between GEFA-FLUG and the German Geophysical Government Agency. It started in 2009 and continued in 2010 with load-carrying flights in eastern and northern Germany.

GEFA-FLUG has more than 25 years of worldwide experiences with using hot air systems for environmental surveys and scientific research (Figure 23.4).

Operational Experiences

Since the early 1980s GEFA-FLUG has successfully used various hot air airship systems in around 25 countries for different purposes. How successful airship operations can be is proved by the fact that GEFA-FLUG, since 1991, has operated two airships for Adler, an international fashion company. Each year they operate 180 days through Germany and other European countries. The programme consists of a mixture between advertising and environmental monitoring, paid for by Adler as its contribution for a better environment.

There have been quite a few monitoring projects all over the world, such as aerial photogrammetry of archaeological sites. An early example in 1982–83 was a four-month photogrammetrical survey of Mohenjo Daro, a 5,000-year-old city in Pakistan. Comparable projects have since then been undertaken in Oman, Syria, Greece, Turkey, Yugoslavia, Egypt, Spain, Israel, and Tanzania, to mention just a few.

Other projects have been the photo documentation of the world-famous castles of Neuschwanstein and the survey of the Rhine and Danube valleys in Austria and Germany together with biologists and other scientists of the World Wide Fund for Nature (WWF). All these projects can be summed up as 'low-range monitoring'. Low-range monitoring or low-range measurement by means of hot air airships provides a very high degree of accuracy.

One highlight of all these projects was the expedition Arctic-Sky in March 1994 to the most northern point of Europe, to fly around Vadsö, the historical mooring



Figure 23.5. Clockwise: The Adler airship flying close to the Castle of Neuschwanstein (Bavaria) to undertake a photogrammetric survey about the castle's building condition – with no other aircraft would this task have been possible to achieve; 'Serengeti shall never die', airship project in Tanzania to act as camera platform for German and international TV stations; the Adler airship (AS 80 GD) at Vadsö (Barentssee), the most northern point of Norway, to commemorate the 1926 and 1928 polar airship flights of Amundsen and Nobile; to be seen as well is the 1926 airship mooring mast.

station of the Amundsen and Nobile airship expeditions of 1926–28 in northern Norway. The mooring mast is still there and is a technical monument today. Several thousand postcards, which had been sold before the flight, were carried onboard the Adler airship to support the Pestalozzi Kinderdorf charity. The widow of General Nobile was patron of this airship expedition. It was the first time in more than sixty years that an airship had flown the Arctic skies from the European part of the planet, and it was the first time that such an expedition was performed under Arctic winter conditions.

Another highlight in 1998, with completely different climatic conditions, was the expedition 'Serengeti shall never die', to commemorate the fortieth anniversary of famous German professor Grzimek's flight expedition in Tanzania in 1958, during which he and his son Michael counted masses of big animals in the Serengeti National Park. The Grzimeks used a light airplane; the GEFA-FLUG team, however, used the Adler airship, which proved to be an excellent stable camera platform for a German TV team to monitor masses of wildebeests and zebras, without annoying them too much.

The project was extremely well covered by the European media. The TV film was repeated more than twenty times in various European channels and, on top of that, the project raised a good deal of financial support for two charity organisations (see Figures 23.5 to 23.7).



Figure 23.6. Poster promoting the airship expedition to the 'Arctic Sky' at the Barentssee.

AS 105 GD: Technical Development

When GEFA-FLUG started developing manned hot air airships in 1985, there was a big potential for research and development (and there is still quite a bit left). No one, so far, had done 'serious' research on hot air airships in a traditional scientific way. Development work had exclusively consisted of the output of practical operation and was done from a 'pilot's point of view'.

In early 1994 GEFA-FLUG accumulated a research and development budget of €750,000, which was partly government funded by the Ministry of Commerce of Northrhine-Westfalia. The programme ran over a period of five years. The target was to get a high-tech hot air airship type-certified and to sell it in a small series. The airship was to be a four-seater. For the scientific part of the project, various Aachen Technical University departments were engaged. The market of these airships is, of course the traditional airship market and the aforementioned environmental monitoring market.

The environmental monitoring market has been opened up since the early 1980s with great technological support from the German Mining Technology, which is one of Germany's first addresses in scientific low-range photogrammetry.



Figure 23.7. The Arctic Sky team beneath the 1926-28 mooring mast of Amundsen and Nobile.

Another objective was to create an airship which costs around €200,000 fully equipped and be able to carry up to four people (see Figures 23.8 through 23.10).

AS 105 GD: Target Definition

- Inflation possible in up to 12 knots ground wind
- Maximum flight speed up to 20 knots and more
- Stable flight characteristics in turbulent air (although the envelope is filled with sloshing hot air)
- Flight time more than two hours
- Certification in the passenger transport category (fare paying- passengers)
- Crew not more than three people plus pilot
- Only one vehicle plus one trailer for transport of airship and crew
- Increase of envelope life time up to 350 hours and more
- Selling price around €200,000

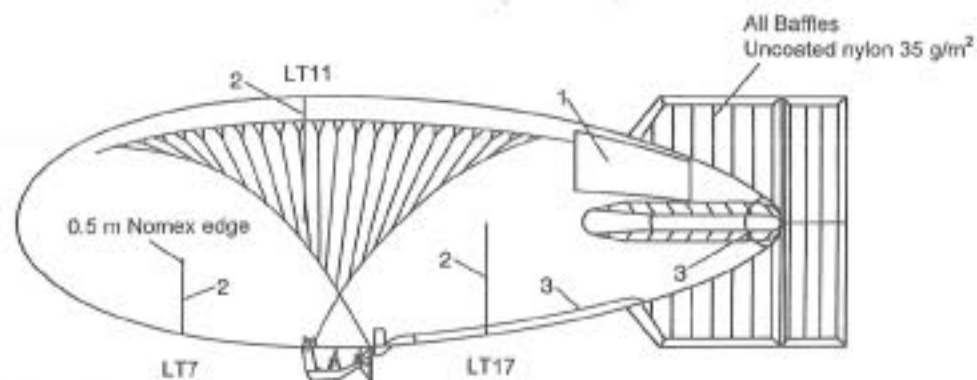

Figure 23.8. The AS 105 GD hot air airship. Fabric envelope HTN90, silicone coated. Fabric membranes made of 35 g/m² uncoated nylon fabric – one in the top, and two in the bottom with 0.5 m Nomex on top of the membranes (helps to avoid air from sloshing forward and backwards) and the top one acts as well as means of trim the ship (front burner heats front envelope chamber or rear burner heats rear envelope chamber). Air distribution sphere, distributes air from the propeller (slipstream) to pressurise the fins. LT 11 means Load tape number 11, position of the top membrane.

AS 105 GD: Scientific Research and Certification Programme

To achieve the aforementioned parameters, much scientific work needed to be undertaken between 1994 and 1998:

- Investigation on aerodynamic parameters (envelope, stabilizers, rudder system, envelope pressurisation, load distribution, and load-taking systems) at the wind tunnel of the Technical University Aachen.

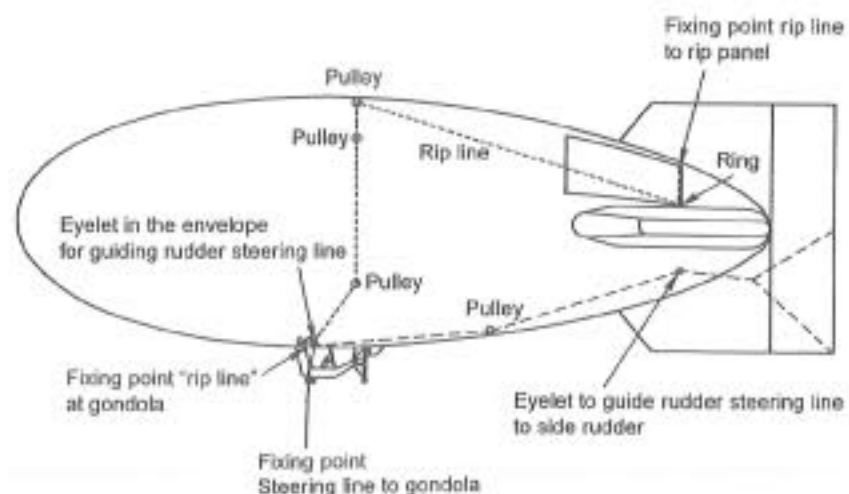

Figure 23.9. The AS 105 GD four-scater hot air airship.



Figure 23.10. AS 105GD instruments and switch panel. The burner control unit can be seen to the right.

- Measurement of aerostatic parameters and heat distribution within hot air airship envelopes by means of computer simulations and loads of temperature sensors fixed to the envelope.
- Research on lightweight and coated envelope fabrics and their lifespan, tensile and tear strength, porosity parameters, UV-stability, and seam and sewing technologies.
- Research on possibilities and limitations of weight reduction of envelope and gondola under stringent aviation certification aspects.
- Flight experiments and computer simulations on aerodynamic – correlated with aerostatic – parameters of hot air airship envelopes with the German Mining Technology and the Technical University Aachen to provide massive feedback and give new and fresh impulses for the complete airship research and development programme.
- Last, but not least, there were no airworthiness requirements for hot air airships to carry more than two people. Consequently, there were no regulations for commercial passenger transport either.

It took almost two years to create these requirements and to get them harmonised Europe-wide.

Table 23.1. Characteristics of the AS 105 GD hot air airship

Characteristic	Detail
Total length (including side rudder)	41 m
Diameter	12.8 m
Envelope fineness ratio	3:1
Volume	3,000 m ³
Lifting gas	Hot air, max 127°C
Envelope fabric	Nylon 6.6, Si coated, 90 g/m ²
Engine, Rotax 582, twin ignition	65 hp
Propeller	Helix, Carbon, 4 blade 1.6 m
Burner, Cameron Shadow 'airship-burner'	Twin burner
Burner fuel, propane	2 × 30 kg
Engine fuel, petrol	30 l, 2 stroke
Envelope weight	Ca. 210 kg
Gondola weight (dry)	Ca. 280 kg
Radio, 760 channel incl. intercom for four people	Dittel
Transponder mode C (optional)	Garrecht
Max allowed takeoff weight (MTOW)	900 kg
Max flight speed	Up to 40 kph
Max flight time (single pilot, max. propane)	Up to 4.0 hours
Flight crew (depending on climatic conditions)	Pilot plus up to 3 passengers
Ground crew (skilled people)	2-3

The Achievement: AS 105 GD

The first certification by the UK CAA for the AS 105 GD was in 1996, using Thunder & Colt twin-seater gondolas. In that configuration, the AS 105 GD is certified for night flying. Certification as a four-seater by the German LBA was in 1999. It was certified for commercial passenger transport by EASA in 2003. Fifty-six aircraft have been manufactured at the time of writing and are operating in more than a dozen countries. The characteristics of the AS 105 GD are given in Table 23.1 (see Figure 23.11).

The Future: The AS 105 GD/6 between Possibilities and Limitations

Since early 2005 another five-year research and development project has taken shape. The AS 105 GD/6 has been accepted by EASA as a six-seater with 5,000 m³ volume. Economical calculations proved that carrying five passengers at a time is definitely another profitable way of operating hot air airships in the worldwide leisure and tourist market. (comparable to hot air balloons) (Figure 23.11).

As an alternative, there is an increasing environmental monitoring market as well, with the airship being capable of carrying 45,000 to 50,000 kg of payload.

At first, the EASA Airworthiness Requirements for Hot Air Airships had to be altered in some safety-related aspects for this project, which took almost one year. The AS 105 GD/6 was developed from experiences gained with fifty smaller ships of the AS105GD type, but has some features which the forerunner did not have.

Almost all major items have been tested at various Aachen Technical University departments, including many wind tunnel experiments. The stabiliser fins, including



Figure 23.11. AS 105 GD four-seater gondola; the double burner unit is to be seen on the front top.

the side rudder, are streamlined now and have again been modified. An electric servo engine has been introduced which operates the side rudder (instead of pulling the rudderlines by hand), being a great relief for the pilot. An electric driven bow and tail thruster might (in a later stage of certification) improve the manoeuvrability of the airship to an even higher level. In addition, there is an autopilot system to control the four burners to keep precisely a given altitude, which is another relief for the pilot and saves 15 percent to 20 percent propane as a result of a more stable heat output and distribution.

A much stronger, but still light, envelope fabric has been developed together with Lückenhaus, one of Europe's leading experts in light, strong, and coated fabrics, well known in the LTA business for its superb long-life balloon fabrics. The weft of the new fabric is almost twice as strong as the warp, taking into account that circumferential forces in airship envelopes are twice as high as longitudinal forces.

In that way, a new airship fabric has been introduced that is twice as strong but only 33 percent heavier than its forerunner. To improve tear strength, even more the fabric is silicone coated from both sides. The fabric development took almost three years with three major steps and a great deal of serious heat and UV testing in the Textile Research Laboratory of the University of Chemnitz using computer simulations and with the help of four months of outside weathering (UV stability) on the actual airship envelope.

The AS 105 GD/6 obtained its EASA permit to fly in August 2008. It has undertaken its full flight test programme and was fully certified by EASA in the commercial passenger category in mid-2010.



Figure 23.12. Airship parade, summer 2009, at Bad Homburg. In the forefront is the GEFA-FLUG six-seater airship with its 5,000 m³ volume.

Pilot Licences and Crew Training

The UK-CAA was the first aviation authority which created a pilot licence for hot air airships, doing so in the mid-1970s. Other European and overseas countries followed over the next decades using the same basic guidelines for pilot qualification.

As a basis, the applicant must possess a hot air balloon license and adequate practical flying experience on hot air balloons. (I recommend 100 hours as PI.) To become a hot air airship pilot, the applicant must undergo certain practical ground handling training and must, of course, take flying lessons (the requirements vary from country to country with a minimum of between 5 and 6 hours; my personal recommendation is 8 to 10 hours) supervised by a certified hot air airship instructor. On the recommendation of the instructor, the applicant finally undertakes a check-out flight with a hot air airship examiner.

The costs for the licence vary with the training being performed either on a hired airship including ground crew or the applicant being trained on his or her own hot air airship. In suitable climatic conditions the training can be performed within one or two weeks, depending on personal skills and the ability to gain aerodynamic knowledge on top of the already existing aerostatic background from ballooning.

A major part of airship operation and its importance which is always underestimated for the newcomer is the ground handling. It is more than just a strong recommendation to train the ground crew extremely well, which normally happens during the new-pilot training. In critical weather situations, only a well-trained and



Figure 23.13. Clockwise from top left: The Leipzig Airship tour covers six European capitals in two weeks' time; the airship is shown here above Budapest; the 'German wings' airship approaches the Berlin Tempelhof airport carrying representatives of the airline; the Linde airship is a four-seater which has been used for company promotional flights; the Coca-Cola airship (four-seater) on a summer tour through Spain, the country where it is based.

well-organised crew will enable the pilot to operate the airship safely close to and on the ground.

The training for the pilot and crew contains some theoretical and a good deal of practical aspects (such as pilot's maintenance and repair on envelope and gondola). Since the early 1990s, GEFA-FLUG has offered airship training courses in southern Germany at Lake Constance, close to the historical birthplace of the Zeppelin airships.

A European Venture: The Airship Alliance

With high-performance hot air airships now available, the worldwide market will definitely increase. Even then, though, it will stay a relatively small and highly specialised market. This diagnosis is the background and backbone for the European airship marketing venture between GEFA-FLUG and Cameron Balloons UK, an 'Airship Alliance' in complementarity and cooperation.

All types of two- and four-seat gondolas and envelopes which both partners have certified so far are interchangeable. Fifty-six GD-type airships have been built and flown on five continents for thousands of hours, certified in many countries by their aviation government bodies, including the UK CAA, the German LBA, or, since 2003, the EASA.

GEFA-FLUG and Cameron Balloons view their Airship Alliance under the aspect of getting prepared for a united world market. The alliance has been extended with the introduction of the six-seater type in 2010. Both partners think it is possible to sell around five airships and later (together with the AS 105 GD/6) up to eight airships per year by GEFA-FLUG and the worldwide Cameron dealer network (see Figure 23.13).